

Viega References

# THE QUALITY BEHIND THE WORLD'S FINEST BUILDINGS.



**viega**

Dalí Museum, St. Petersburg, Florida, USA



more than

20

examples of top  
quality from Viega

4

Public buildings

16

Health sector

24

Office buildings and hotels

30

Service

10

Science and education

20

Leisure and sport facilities

26

Industry and transport

# QUALITY FROM VIEGA IN APPLICATIONS WORLDWIDE.

Viega has been a leading pioneer in the sanitation, heating and air-conditioning industry for over 115 years. Our products are in use all over the world, demonstrating our top quality standards in many practical applications. Whether for a detached house, an office complex or an industrial building: Our systems can be scaled according to requirements, and offer the right solution for any application.

And though we celebrate every single connector we install, there are some projects of which we are particularly proud. Not because they are necessarily the biggest, most expensive or most prestigious, but because each of them confronted us with quite specific challenge. Extreme weather conditions, stringent safety requirements or unconditional reliability demands are among the criteria that our products, service and know-how have to meet in order ultimately to deliver a successful project.

It's always a great feeling for us to be a part of something really big. And we are constantly striving to develop new innovations and make our products ever better. Because we are committed to absolute top quality, and intend to keep delivering it in future.

**Viega. Connected in quality.**

# A SYMBOL OF FREEDOM THAT IS ALSO A LANDMARK IN TERMS OF FIRE PROTECTION.

Statue of Liberty, New York

93 m

high

4,500,000

visitors per year

## Statue of Liberty

In the close confines inside the statue, visitor safety is of course a high priority. As part of an extensive renovation project, a new fire protection design was implemented. A key new feature of it was a highly sensitive smoke detector system: A complex network of vents routes even the minutest quantities of smoke to the fire alarm sensors. The fire alarm is now triggered earlier, assuring maximum safety for visitors and for Lady Liberty herself. For the pipes carrying the fire extinguishing water the renovation team chose the Profipress copper piping system (to US standard), based on that material's proven qualities of durability and cost-effectiveness.

## Location

New York, USA

## Year

2007

## Type of project

Renovation

## Product

Profipress (according to US standard)

## Use

Fire extinguishing water system



## Public safety

In public buildings, where large numbers of people gather, fire protection is a prime safety concern. That is why Viega focuses on fire protection as a key competency, offering a wide range of innovative solutions to minimise the risk of fire.

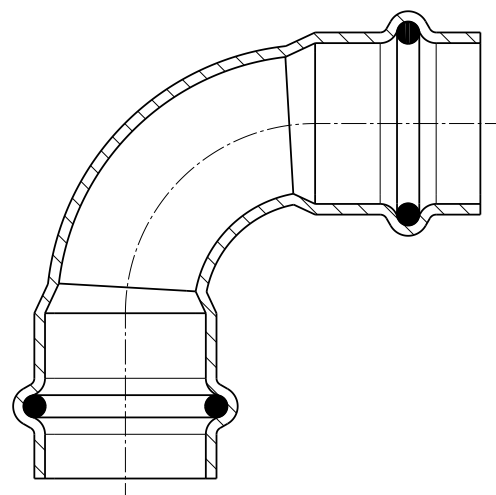

**Product** Profipress 90° elbow

**Application areas** Potable water, heating systems, compressed air, cooling water pipelines, industrial construction and plant manufacture

**Description** The press connector system made from copper, gunmetal and silicon bronze is a real classic in the installation technology world. The high-grade materials make it suitable for a wide range of applications, and with the patented SC-Contur it provides absolute safety.

# 34,280 m<sup>2</sup>

office space

# 45 km

pipng

Maximum safety for  
an entire nation



## Pentagon

The Pentagon has been home to the US Defense Department since 1943 – and the prestigious building of course demands high standards of quality and cost-effectiveness as a top priority. So it was that when the time came to renovate the complex, the management responsible chose the highly durable Profipress copper piping system (to US standard) for its sanitary and heating installations.

**“The press connecting technology means the pipe connections are much tighter and more secure than soldered connections. And the press technique meant that the time to install was basically halved”,** explains Marv Wheeler from installation contractor Southland Industries.

He points out some more plus-points of Profipress in addition to its durability: In the USA copper pipes used to be soldered. Since the launch of Profipress onto the US market, however, use of the ‘Made in Germany’ cold press connecting technology has been spreading ever wider.

## Location

Washington, D.C., USA

## Year

2011

## Type of project

Renovation

## Product

Profipress (according to US standard)

## Use

Sanitary and heating systems

60600

is the building's dedicated ZIP code

140,000 m<sup>2</sup>

area

660 m

length



Top quality all  
year long

© Architects: JSK; Photo: HG Esch Photograph

**The Squire**

“The Squire” at Frankfurt Airport was opened in 2011. Its futuristic architecture is ground-breaking. The managers of “The Squire” mega-project are glad to rely on Viega’s Sanpress Inox potable water and Prestabo heating pipe systems.

Many of the shops in “The Squire” are open round the clock. That means the piping is working continuously too. In view of that, Viega sets extremely high standards for quality control on all its products, subjecting each individual connector to stringent testing.

**Location**

Frankfurt on the Main, Germany

**Year**

2011

**Type of project**

New construction

**Products**

Sanpress Inox, Prestabo

**Use**

Potable water and heating installation

# 10,750 m<sup>2</sup>

heated area

# approx. 22

fashion firms

# more than 50

heating and cooling circuits

Ideal climate at every time of the year

## Labels Berlin 2

Including fashion showrooms and attractive work spaces, "Labels Berlin 2" in the district of Friedrichshain is a prime example of exciting architecture providing a hub where creative minds can flourish. A particular challenge for the building services was to maintain uniform room temperatures. Even with all the spotlights shining on the latest fashion collections and generating intense heat, the temperatures in adjoining rooms have to be kept constant.

The challenge was easily met thanks to the Fonterra radiant heating and cooling system. The system's 50 heating and cooling circuits covering a storey ceiling space of 4,750 m<sup>2</sup> are backed by additional 70 circuits on approximately 6,000 m<sup>2</sup> of floor space. The result is an ideal working climate in every room, regardless of the time of year and the heat input into individual rooms.

### Location

Berlin, Germany

### Year

2009

### Type of project

New construction

### Product

Fonterra

### Use

Radiant heating and cooling



**Location**

Munich, Germany

**Year**

2007

**Type of project**

New construction

**Product**

Sanpress Inox

**Use**

Fire extinguishing water supply

**Everything in stock – every day**

Major projects also pose major challenges. In most cases subject to stringent specifications and tight deadlines. To ensure that our customers remain operational at all times, Viega's in-house logistics set the industry benchmark in terms of product availability and service backup. Looking to the future, Viega is continuing to expand capacity and now has almost 100,000 storage positions. That provides space for over 17,000 products to be held permanently in stock and so immediately available. This covers the current range of products as well as many spare parts. So reliability starts from the moment an order is placed.

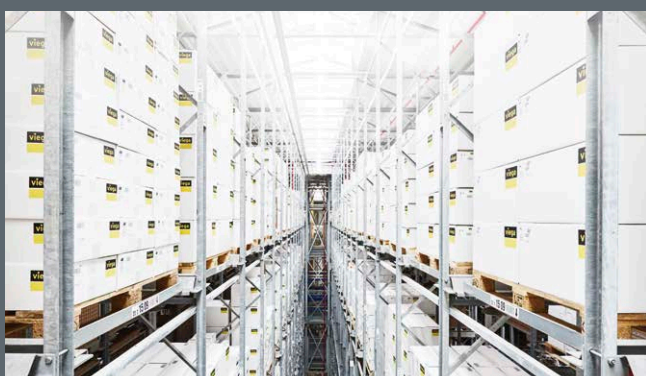
**BMW World and BMW Museum**

The BMW World, incorporating the BMW Museum, at the car-maker's Munich home base is an architectural pearl. Some 20,000 buyers visit the attraction to collect their new cars each year. The vehicles waiting in this facility pose a major fire risk however – primarily due to the quantities of fuel and other service products in them.

To counter that risk, and in order to comply with Bavarian regulations governing the garaging of vehicles, BMW demands maximum safety: The building's subterranean levels are made entirely of 100 percent non-combustible materials. In the event of a fire, a "wet" sprinkler system is automatically activated. Almost all the pipelines for potable water and fire extinguishing, as well as the nitrogen lines, are constructed from the Viega system range. Depending on the application, they are either all stainless steel from the Sanpress Inox range, or from the Sanpress range featuring gunmetal connectors.

It meant that the engineers could in principle cover all applications with one piping system. This simplified the entire logistics and on-site storage process.

# SUPREME QUALITY HANDLING THE TOUGHEST CONDITIONS.

**Bharati Research Station, Antarctica**

some **25** people working on-site all year round

## **Bharati Research Station**

The research station in the endless ice was established on behalf of the Indian government. It carries out research into climate change and marine biology. Extremely tough and durable potable water and heating installations were an essential requirement to allow the researchers to conduct their work under the extreme conditions of the Antarctic winter.

What's special: Glycol is added to the hot water to prevent it from freezing at outside temperatures down to minus 40 °C. So the Prestabo system was installed to distribute the heating. Kerosene is used to generate heat and power, because it remains liquid down to minus 54 °C. To aerate the tank, the engineers installed the Viega Sanpress Inox G piping system – because of its permanent resistance to the media being transported.

Both media impose high demands on the piping systems – demands which Viega's systems meet with ease, so enabling safe working under the most extreme conditions.

**Location**  
Antarctic

**Year**  
2012

**Type of project**  
New construction

**Products**  
Sanpress Inox, Sanpress Inox G,  
Prestabo, Easytop

**Applications**  
Potable water and heating installation

300 km/h

wind speed

-40 °C

outside temperature

2,000 m<sup>2</sup>

area



#### Guaranteed tested

Providing the right product for an extreme situation is one thing. The ability to assure such high reliability and ruggedness across the entire product range is the result of product testing and quality control based on extremely high standards. For Viega, that means that every single connector is subjected to the most stringent test procedures before it leaves our factory. This includes visual inspection under the trained eyes of our staff, as well as precise scanning by means of the most modern camera and laser technology. So that our customers can rely on each and every component with 100 % assurance, in any situation.

36

million dollars construction cost

1,400 m<sup>2</sup>

area

More than

1,500

masterpieces of German engineering

**Location**

St. Petersburg, Florida, USA

**Year**

2011

**Type of project**

New construction

**Product**

Profipress (according to US standard)

**Use**

Potable water installation

**Dalí Museum**

The new Salvador Dalí Museum building houses art works, books and personal documents in a permanent exhibition. The concrete walls of the approximately 1,400 m<sup>2</sup> building are almost half a metre thick, and the entire building is designed to withstand a category 5 hurricane.

For the potable water supply, contractor Feddon Mechanical LLC installed several hundred metres of copper piping together with connectors from the Profipress system (to US standard) up to 4 inches in size.

**“The time pressure was very high. Thanks to Profipress, we were able to cut the working time by 30–40 %. And thanks to the technical support from Viega, we were able to utilise all the system’s benefits”**, recalls Jim Stark, vice-president of Feddon Mechanical LLC.

Thanks to its quick processing capability, the cold pressing technology is far superior to other methods, including in terms of installation time. Huge time-saving is possible depending on the chosen system. In practical terms, this enables, on the one hand, work to be conducted efficiently, while on the other hand, enabling more projects to be handled in the same period.

27,000 m<sup>2</sup>

area

1,900 m<sup>2</sup>

glass structure

6,000 m

copper piping

Prestigious architectural design embodying the finest craftsmanship



© à COOP HIMMELB(L)AU, Sergio Pirrone

### Musée des Confluences

The “Musée des Confluences” in Lyon is one of the most prestigious projects in the Rhône-Alpes region in recent years. The building covers an area of 27,000 m<sup>2</sup>. A gigantic concrete plinth serves as the foundation of the 1,900 m<sup>2</sup> glass construction and the “cloud” – the 11,000 m<sup>2</sup> section housing the exhibition rooms.

Contractor Jean Moos from Amplepuis was chosen to carry out the installation work, also including the potable water supply to the sanitary facilities. The Profipress copper piping system was deployed. Moos technical director Pascal Magnin reports that Viega’s press connecting technology provided the ideal installation method. The contractor installed 6,000 metres of copper pipe in total, using Profipress connectors in DN 15 to DN 35 sizes.

#### Location

Lyon, France

#### Year

2014

#### Type of project

New construction

#### Product

Profipress

#### Use

Potable water installation

musée des  
confluences

RHÔNE

LE DÉPARTEMENT

# 125,512 m<sup>2</sup>

total area

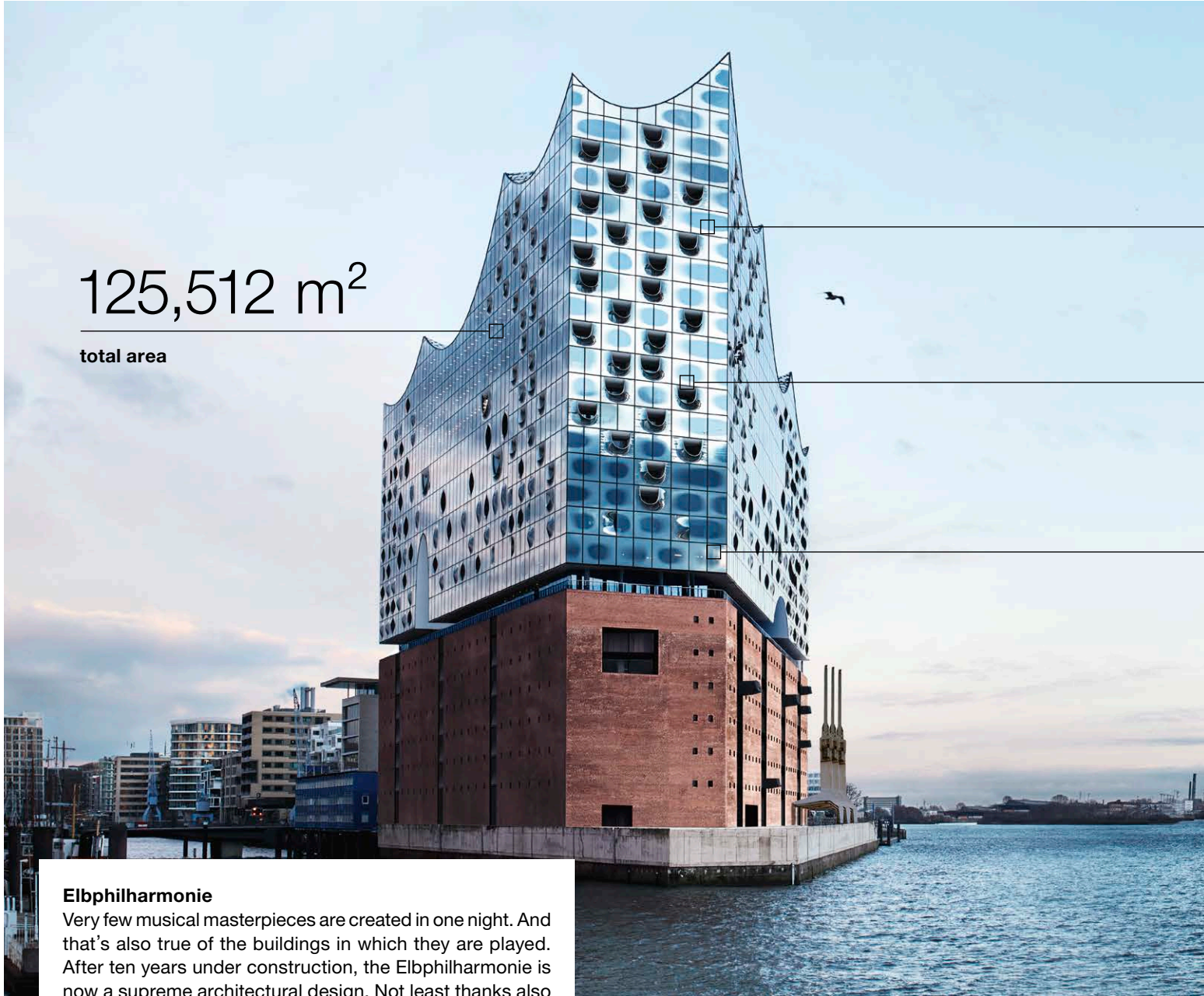

## Elbphilharmonie

Very few musical masterpieces are created in one night. And that's also true of the buildings in which they are played. After ten years under construction, the Elbphilharmonie is now a supreme architectural design. Not least thanks also to the skills of many experts such as sanitation, heating and air-conditioning contractor Jens-Peter Rücker. The Hamburg-born professional and his staff worked on the project with full-blooded commitment throughout its lengthy construction period. So very few people are as familiar as Rücker with every inch of the Elbphilharmonie complex.

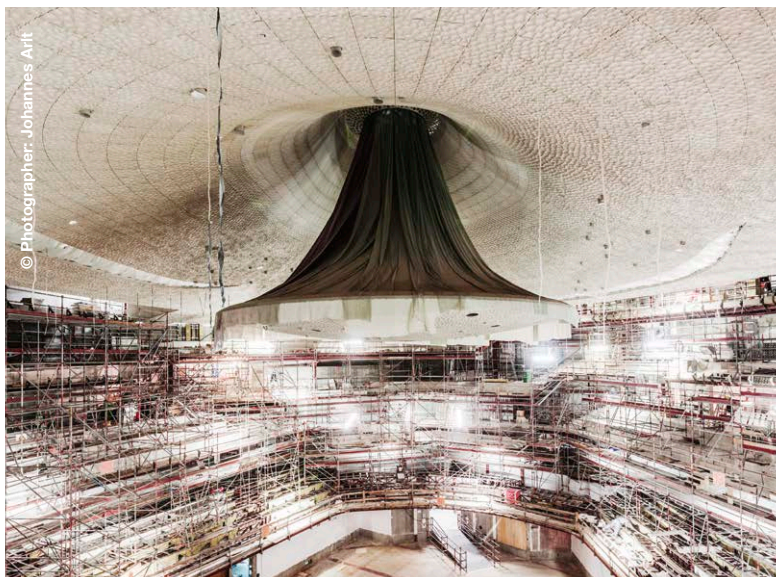

## Location

Hamburg, Germany

## Year

2017

## Type of project

New construction

## Product

Profipress

## Use

Potable water and heating installation

# 200,000 t

total weight

# 2,800

seats

**Optimum conditions for an  
extraordinary design language**

## Our customers' partner

Our customers' success is not an incidental matter to Viega – it is what motivates us in our daily work. We see ourselves as a partner who can supply products and innovative solutions. And this includes personal contact, support in the form of problem-solving suggestions and direct advice for all kinds of issues. This can, of course, involve our own products – but just as well current market matters. Therefore we already provide support to our customers in project planning stages, and continue this while the project is being carried out.

© Photographers: Maxim Schulz

Jens-Peter Rücker, managing director of sanitation, heating and air-conditioning contractor A.C. Vorwald & Sohn GmbH, explains the special features of a major project such as the construction of the Elbphilharmonie in Hamburg in a short interview.

**The construction of the Elbphilharmonie was without doubt a hugely exciting project. Did it pose special challenges for you as a sanitation, heating and air-conditioning contractor?**

“The acoustically optimised sweeping form of the main hall extends practically all through the building. As a result, the heating and potable water pipes are routed not only vertically but also horizontally.”

**You purposely chose the Profipress press connector system. Why?**

“Firstly, Profipress provided the extremely wide range of moulded pieces that we needed. Secondly, SC-Contur assures a high degree of safety.”

**Why was that so important for the Elbphilharmonie in particular?**

“Owing to the differing geodetic levels of the piping layout, in the central leakage test of the individual sub-networks almost every connector was subject to a different test pressure. The SC-Contur feature of the Viega connectors ensures the essential tell-tale leakage across the entire pressure range of a leakage test. And that is a safety feature which makes Viega connectors unique.”



220  
beds

70,000 m<sup>2</sup>  
area

700  
new patients  
per year

The best reasons for  
focusing on potable  
water hygiene

**Location**

Moscow, Russia

**Year**

2011

**Type of project**

New construction

**Products**

Sanpress Inox, Prestabo, Pexfit Pro,  
Viega Eco Plus, Advantix

**Use**

Potable water and heating installation

**Paediatric oncology**

The Dmitry Rogachev scientific and clinical centre for paediatric haematology, oncology and immunology was established in Moscow in 2005. In view of the social significance of the centre, the highest safety demands were imposed on all the technical building systems – particularly in terms of maintaining potable water quality.

After all, any faults in those systems might have serious consequences. So to minimise the risk the centre opted for Viega systems. The installation contractor installed the water treatment systems and potable water riser pipes using the Sanpress Inox stainless steel piping system. To distribute the potable water to the building's different floors, on the other hand, it chose the Viega Pexfit Pro plastic piping system.

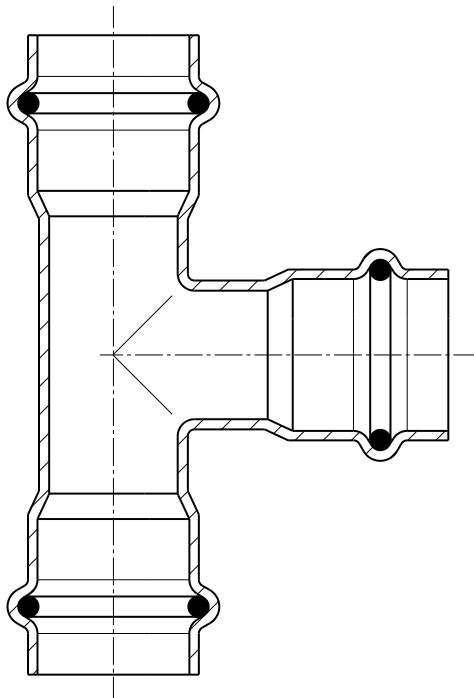

**Product** Sanpress Inox T-piece

**Application areas** Potable water, heating/radiator connection, rainwater, compressed air systems, agriculture, industry

**Description**

The press connector system comprises a wide range of products for installation in building services systems and for industry. Thanks to the use of high-grade stainless steel, it is ideally suited to potable water installations, and guarantees maximum hygiene.

### Expertise in potable water

Potable water is a vital concern in medical facilities. The cleanliness of such highly sensitive areas is essential to patients' health. Viega not only offers a wide range of products and solutions for assuring potable water quality, but has also made the subject one of its core competencies.

To achieve sustainable handling of potable water, designers and contractors must be able to reliably assure that its quality is maintained at all times. Because the characteristics of potable water can change during installation, such as a result of contact with materials, heat-up, or periods of stagnation. So only technically high-grade solutions and materials can assure the safety of potable water. For that reason, top quality standards from Viega start right from the material selection stage. Only materials that meet the strictest standards can be used. Viega puts great store by only using materials that exclude any possibility of potable water quality being compromised.

But Viega's engagement with the subject of potable water extends well beyond the development of piping systems. The company has for years been supporting trade professionals and planners with innovative product solutions, comprehensive service backup and related seminars. The prime objective is to share knowledge, and to ensure that it is deployed where it is needed. As is the case with the products that feature the Viega Hygiene+ function which helps to prevent stagnation and critical temperatures in potable water installations. The approach also entails holding seminars covering all the latest potable water ordinance. And detailed advice from the Field Service team rounds off the comprehensive backup provided.

# 21 ha

site

# 34,000 m<sup>2</sup>

building

Assured potable  
water quality made  
easy



## Ahuja Medical Center

At the Ahuja Medical Center university hospital, the versatility of Viega's system solutions offered the possibility to implement open-space heating using the American Viega ProRadiant system and to execute the potable water installation with Profipress (to US standard).

Dave Kause from the installation contractor Smith & Oby explains: **"We use Viega systems on lots of our projects. We have always had good experience with Viega products, and we intend to keep on using them."**

Smith & Oby president and CEO Mike Brandt is likewise convinced that complicated installations will pose no worries for the company in future thanks to Viega Profipress. **"The Viega press system is easier to extend than a soldered installation"**, he explains. **"And we don't need a permit to work with naked flame."**

## Location

Beachwood, Ohio, USA

## Year

2011

## Type of project

New construction

## Products

ProRadiant (American radiant heating and cooling system), Sanpress Inox, Easytop, Profipress (to US standard)

## Use

Radiant heating and cooling and potable water installation

**Johanniter-Klinik at Rombergpark**

The exclusive use of state-of-the-art technology was a key feature of the Rombergpark health centre right from its construction stage. It was in fact the only way to ensure that the extremely tight deadline for completion within less than two years could be met. Consequently, minimising interfaces between different systems was also a key factor. It was for that reason that sanitation, heating and air-conditioning contractor Gebr. Lorenzen opted for products from the Viega portfolio of systems.

**“There were always a dozen or so staff on-site working on the heating and sanitary installations at any given time, depending on construction progress. When the working processes and tools for all piping systems are the same, things are so much easier”,** explains one of the experts from Gebr. Lorenzen.

**Location**

Dortmund, Germany

**Year**

2015

**Type of project**

New construction

**Products**

Sanpress, Prestabo, Raxofix

**Use**

Potable water and heating installation



200  
beds

13,700 m<sup>2</sup>  
extension

25,000 m  
piping systems

A place where  
innovations  
converge



840 m

circumference

75,000

capacity

Allianz  Arena

### Allianz Arena

Whether you're a football fan or not, a visit to the Allianz Arena is a real thrill. Especially when you are a guest in one of the exclusive boxes, which are fitted out according to the individual wishes of their hirers – including a bathroom with shower.

That level of custom outfitting demanded truly “champion” performance from the sanitation, heating and air-conditioning contractors during the stadium’s construction. The Allianz Arena exclusively features the Steptec pre-wall system. It is very quick to install, and is highly flexible. This allowed the sanitation experts to preassemble the sanitary facilities in the workshop. And, as such, just a few manoeuvres were required on site to achieve the perfect fit. Even unusual designs could be executed without problem.

### Location

Munich, Germany

### Year

2005

### Type of project

New construction

### Products

Profipress, Sanpress, Steptec

### Use

Pre-wall installation

45,500 m<sup>2</sup>

illuminated  
surface area

Piping systems that are top-league  
players every day



**Product** Visign for More 104

**Finishes** Aluminium chrome-plated, chrome matt, stainless steel colours, special colour, metallic colour, gold-plated

**Description** Thanks to their extremely high-end materials and design, Visign for More flush plates are a highlight in any bathroom. They are compatible with all Viega cisterns and pre-wall systems, and available with either manual or touchless sensory flush actuation.



© Photo: Peter Barrow

**Aviva Stadium**

Architecturally striking in design, the stadium is located in the midst of a residential area. While three of the sides feature four-level stands, the north end comprises just a single level, so as not to block the sunlight from the neighbouring homes.

In order to provide visitors to the Aviva Stadium with optimum water supply and heating throughout the year, the entire potable water installation was executed with Profipress in copper, while the galvanised steel Prestabo system was used for the heating installation. The planners were impressed above all by the functional SC-Contur and the double pressing technology. The contract was won even though press connectors had up to that point been practically unknown in Ireland.



**Location**  
Dublin, Ireland

**Year**  
2010

**Type of project**  
New construction

**Products**  
Profipress, Prestabo

**Use**  
Potable water and heating installation

**Location**

Chicago, Illinois, USA

**Year**

2011

**Type of project**

Renovation

**Product**

Profipress (according to US standard)

**Use**

Potable water and heating installation

**Soldier Field**

Soldier Field was opened in 1924 under the name of Grant Park Municipal Stadium, and was subsequently renamed in honour of America's fallen soldiers. Construction contractor Hill Mechanical Corp. took on the 20-month renovation project in 2011, including modernisation of the building services. Although not stipulated in the specification, Hill Mechanical requested the option to use Viega Profipress (to US standard).

The renovation of the complete installation comprised some 8,200 running metres of piping, in sizes from ½" to 4", so it was essential for Hill Mechanical to use Profipress if it was to meet the completion deadline.

**"If the 25 installers we deployed for Profipress had had to solder all the joints, we would not have finished the job on time",** states project manager Russ Nelson.

61,500

capacity

58 km

piping

**Setting new standards  
founded on tradition**





354 m

maximum height

230

bidet elements

1,400

Viega WC elements  
installed

The new standard for  
custom luxury

#### **OKO Business Centre**

The building complex in the Russian capital Moscow consists of two towers: the 49-storey Office Tower and the 85-storey Apartment Tower – each featuring custom interior design. The developers were especially focused on assuring the long-term safety of all the technical building systems, including the sanitation. Consequently, Viega's innovative and highly reliable technology was installed throughout the sanitary facilities.

Advantix Vario shower channels were the first choice for the floor-level showers. Their elegant design, ease of installation and fast drainage capacity combined with a low installation height were persuasive arguments. For the pre-wall installation, the designers opted for Viega Eco Plus: In total, over 1,400 WC elements in combination with Visign for Style flush plates were installed.

#### **Location**

Moscow, Russia

#### **Year**

2015

#### **Type of project**

New construction

#### **Products**

Advantix Vario, Eleganta,  
Visign for More,  
Viega Eco Plus

#### **Use**

Pre-wall technology,  
drainage technology



51

storeys

1,750

rooms

153 m

Height

Flawless potable water supply  
on every floor**Hotel Sheraton New York**

The Hotel Sheraton New York is a luxurious home-from-home with a rich history. Thanks to Viega Profipress (to US standard), the building now has a new potable water installation. Contractor Infinity Mechanical installed all the piping systems throughout the hotel. The renovation project was the first time that Infinity Mechanical CEO Joe Alagna had encountered Profipress.

**“Everything went smoothly. The connectors were very high quality. We didn’t have a single leak after pressing. I was impressed!”** Alagna concludes.

Most of the connectors were ½" to ¾" size, with the main pipes being between 1½" and 2". Since completing the Sheraton project, Infinity Mechanical has been keen to work with Viega products on all its installations.

**Location**

New York, USA

**Year**

2011

**Type of project**

Renovation

**Products**

Profipress (to US standard), Prestabo

**Use**

Potable water installation

# 150 KM OF PIPING ALONG FOR THE ADVENTURE.

Serenade of the Seas



2,500  
passengers

850  
crew

16

bars, clubs and  
lounges

150 km

piping

© Photo: Royal Caribbean Cruises Ltd.

**Serenade of the Seas**

The “Serenade of the Seas” is one of the largest cruise ships ever built in Germany. The floating luxury hotel’s keel was laid at the Meyer shipyard in Papenburg. The ship’s futuristic design imbues it with a real aura of glamour. Royal Caribbean applies high standards of safety and comfort in line with its brand.

Guests are supplied with more than 1.5 million litres of potable water a day. Those 600 litres per passenger are not “consumed” in the many bars and restaurants, however, but in a sauna with pool and steam room, as well as by two more pools and three whirlpools on deck. The water is distributed by the Profipress piping system.

A special feature of the Profipress system is Viega’s “cold” pressing technique. Its advantages are particularly revealed in the tight space available on-board ship: The pressed connections are quickly fitted, and firmly secured by SC-Contur, and no heat or sparking is involved in their installation as in the case of welded joints otherwise used for larger pipe dimensions. This safety aspect is particularly vital in the event of repairs being needed while at sea.

**Location**

Papenburg, Germany

**Year**

2003

**Type of project**

New construction

**Product**

Profipress

**Use**

Potable water installation

5,000 m<sup>2</sup>

area

A reliable partner  
who is an expert in its field

25

years experience



Kaasveredeling Kruijt

### Kruijt cheese processing plant

What makes the project at the Kruijt cheese processing plant so unusual are the high pressures and the use of cleaning agents – both essential for in-situ cleaning of the production machinery. Arie Plomp from contractor Plomp Installatietechnik explains:

**“Those conditions cannot be handled by a standard installation. They demand the specialist know-how of an experienced contractor. We quickly realised that Viega was the partner we were looking for.”**

The stainless steel pipes and press connectors from the Viega Sanpress Inox system were ideal for the job. One of the reasons is because the press system carries the cleaning agents for production machinery reliably and safely. Arie Plomp continues:

**“Viega met the challenge to perfection. The company conducted tests based on our specifications, and even gave a guarantee that we could use the Sanpress Inox system in the application even up to 20 bar.”**

#### Location

Zegveld, Netherlands

#### Year

2014

#### Type of project

New construction

#### Product

Sanpress Inox

#### Use

Industrial plant

### Tested safety

Whether in public buildings, hospitals, hotels, museums, on-board ships or in industry: every application area entails specific requirements and imposes its own standards which must be met. So for Viega it is a matter of course that all the products in its extensive range more than comply with applicable regulations and meet national and international standards for the specific industry in which they are used.



7

development centres  
worldwideWell conceived down  
to the smallest detail

1,600

employees

**Leica Microsystems**

The global corporation is a byword for supreme optical precision. The correspondingly high process demands at the company's headquarters location in Wetzlar made it necessary to replace all the no longer entirely reliable media piping networks – and all without interrupting production of course.

In addition to this, a very special task involved replacing the pipe network that supplies the grinding medium for spherical surface treatment of lenses. To ensure that the Viega systems fulfilled the high quality demands for such critical media, the various piping systems were subjected to weeks of testing under real-world conditions. The judgement: **“The unified Sanpress Inox stainless steel system was the only one to attain the specified durability with long-term reliability.”** So the way was clear for a full switch to Viega systems.

**Location**

Wetzlar, Germany

**Year**

2006

**Type of project**

Renovation

**Products**

Sanpress Inox, Profipress G

**Use**

Compressed air, gas, potable water and heating installation

An aerial view of a construction site showing numerous vertical rebar columns rising from a concrete slab. Workers in safety gear are scattered across the site, some near stacks of materials and others near the rebar structures. The scene is brightly lit, suggesting a clear day.

# IT'S YOUR PROJECT. SO WE LEAVE NOTHING TO CHANCE.

**Viega Service**

Professional service starts even before the first sod has been turned, and is sustained throughout the project. That is exactly what Viega delivers. And that is why you can rely on a service that will provide you with all the backup you need – before, during and after completion of the project.

#### **Always there for you: our Field Service**

Nothing can replace personal contact. So whenever you need help and assistance you can call not only upon our technical advisers but also upon our large team of Field Service staff who are always at your disposal. You will benefit most especially from the expert advice we provide. Because all our design consultants are reliable partners capable of providing you with specially tailored recommendations to meet any challenge.



### Our know-how working for your success

On large-scale construction projects it's not only the material requirements which are higher. The greater the complexity and scale of an installation, the greater the demands on the contractors involved. This is just where Viega is of greatest benefit, including through the many practical seminars it offers to customers at its 15 seminar centres worldwide. In this way, Viega is able to share its more than 115 years of experience and vital know-how with its customers.

Viega also assures top quality in its customer relations. A large staff in the internal administration and field service teams, as well as at the company's service centres, ensure that expertise assistance is on hand at virtually any time. Detailed technical information on all the company's products is also available at [viega.com](http://viega.com)

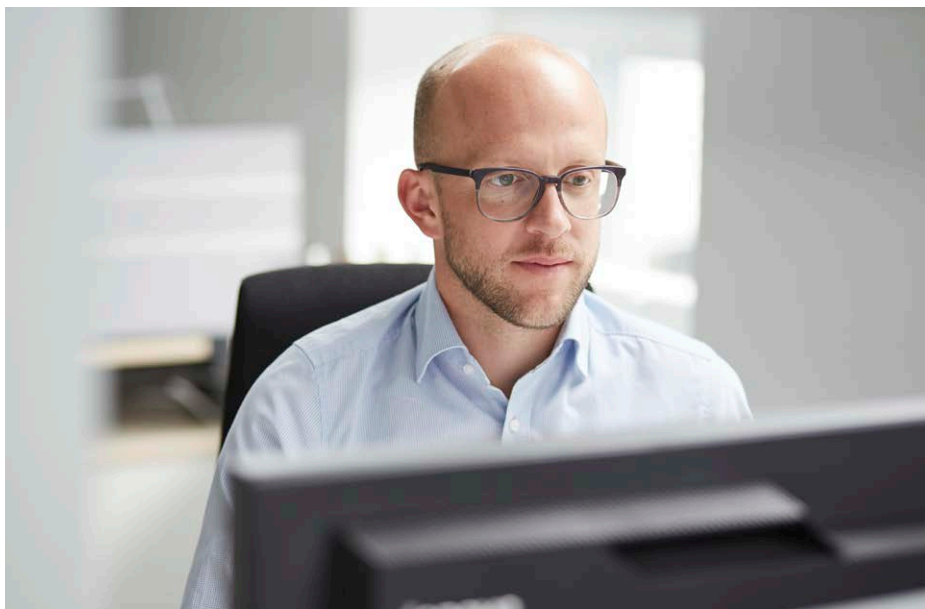

Expert staff are on hand to assist you at any time via our free Service Hotline. Whether your questions relate to technology matters or planning, we will be glad to help.

You will find more information on all Viega reference projects at [viega.com](http://viega.com)

